



## FEATURES

- Input and output modules for interfacing between CPU and external input devices or loads
  - IAC: AC input (yellow)
  - OAC: AC output (black)
  - IDC: DC input (white)
  - ODC: DC output (red)
- Excellent transient noise immunity
- Breakdown voltage: 4,000 V between input and output
- Zero-cross switching for reducing EMI
- LED operation indication types available

## TYPICAL APPLICATIONS

1. Optimum for minicomputer and microcomputer use, and for feed back control process control systems. Robot, NC machine, Automatic Assembling machine.
2. Programmable controllers controls for motors, solenoids and solenoid valves.

Compliance with RoHS Directive

## ORDERING INFORMATION

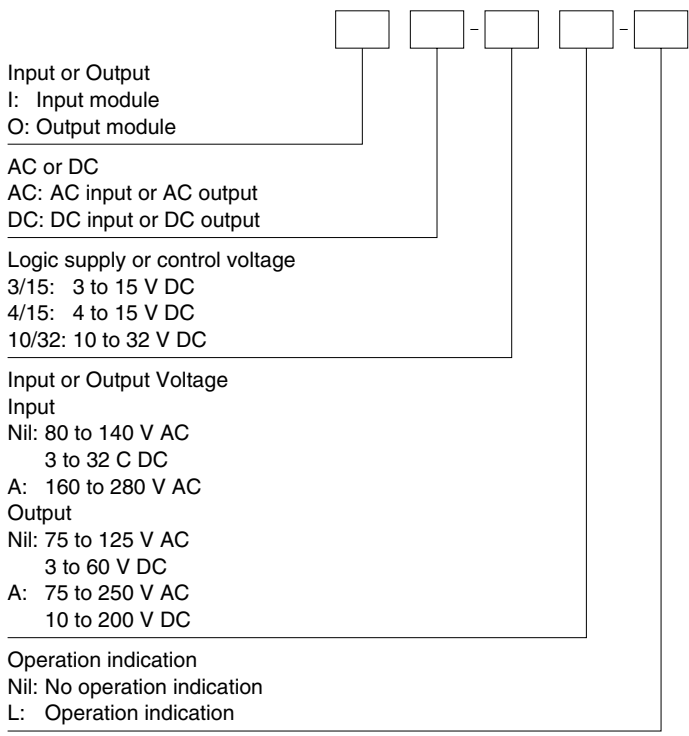

## EXAMPLE OF I/O SYSTEM CONSTRUCTION

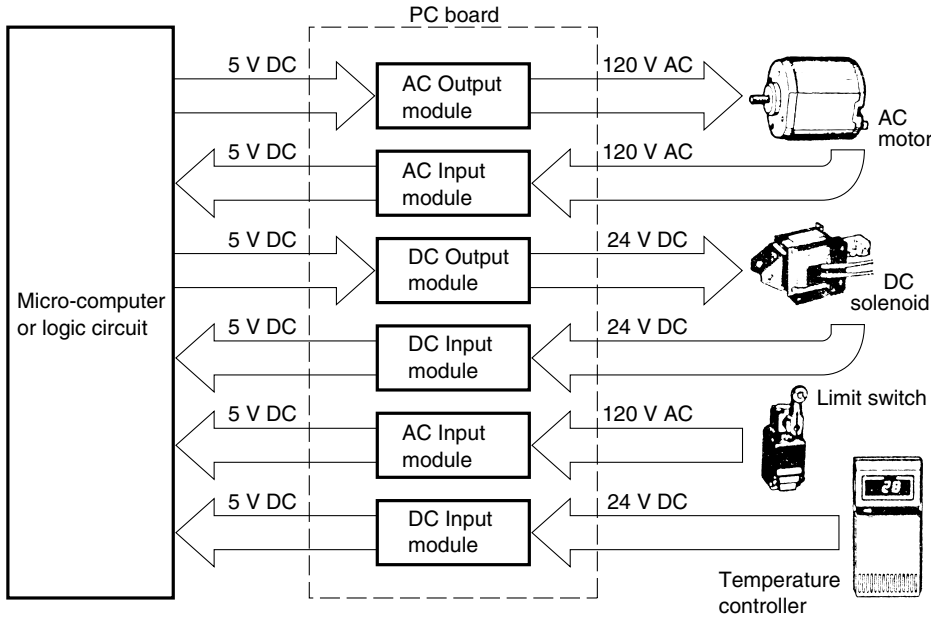

Recently, the microcomputer shown in the left has come into use, with a rapid increase in the use of feedback control for process controllers. As an input/output interface relay, it represents a fast responding interface with long life, noiseless, PC board mounting facility, making circuit design and manufacture simple, and providing amplification of maintenance with space saving. Our company's I/O relays have been grouped for use with either AC or DC devices as AC output type, AC input type, DC output type, and DC input. In addition, the I/O use relay is modularized identically, responding to the various load types for PC board mounting. Because combinations can be freely used, circuit design has been greatly facilitated. Accordingly, the above diagram of interface PC board mounting is a practical construction which can be used.

## TYPES

### Input modules

Type	Logic supply voltage	Input voltage	Part No.	
			No LED	With LED
AC	4 to 15 V DC	80 to 140 V AC	IAC4/15	IAC4/15-L
		160 to 280 V AC	IAC4/15-A	IAC4/15-AL
	10 to 32 V DC	80 to 140 V AC	IAC10/32	IAC10/32-L
		160 to 280 V AC	IAC 10/32-A	IAC10/32-AL
DC	4 to 15 V DC	3 to 32 V DC	IDC4/15	IDC4/15-L
	10 to 32 V DC	3 to 32 V DC	IDC10/32	IDC10/32-L

Standard packing: Carton: 20 pcs.; Case: 200 pcs.

Note: Please refer to the Standards Chart for products that have been certified.

### Output modules

Type	Logic supply voltage	Output voltage	Part No.	
			No LED	With LED
AC	3 to 15 V DC or 4 to 15 V DC	75 to 125 V AC	OAC3/15	OAC4/15-L
		75 to 250 V AC	OAC3/15-A	OAC4/15-AL
	10 to 32 V DC	75 to 125 V AC	OAC10/32	OAC10/32-L
		75 to 250 V AC	OAC10/32-A	OAC10/32-AL
DC	3 to 15 V DC or 4 to 15 V DC	3 to 60 V DC	ODC3/15	ODC4/15-L
		10 to 200 V DC	ODC3/15-A	ODC4/15-AL
	10 to 32 V DC	3 to 60 V DC	ODC10/32	ODC10/32-L
		10 to 200 V DC	ODC10/32-A	ODC10/32-AL

Standard packing: Carton: 20 pcs.; Case: 200 pcs.

Note: Please refer to the Standards Chart for products that have been certified.

## SPECIFICATIONS

Rating (at 20°C 68°F, Voltage ripple of logic side: less than 1%)

### 1. Input module

		IAC 4/15	IAC 4/15-L	IAC 10/32	IAC 10/32-L	IAC 4/15-A	IAC 4/15-AL	IAC 10/32-A	IAC 10/32-AL	IDC 4/15	IDC 4/15-L	IDC 10/32	IDC 10/32-L	Remarks
Input side	Input voltage	80 to 140 V AC				160 to 280 V AC				3 to 32 V DC				
	Input current, Max.	5 mA (100 V)				5 mA (200 V)				20 mA (32 V)				
	Operate voltage, Max.	80 V AC				160 V AC				3 V				
	Release voltage Min.	10 V AC				20 V AC				0.8 V				
Logic side	Logic supply voltage	4 to 15 V		10 to 32 V		4 to 15 V		10 to 32 V		4 to 15 V		10 to 32 V		
	Logic supply current, Max.	15 mA								15 mA				at max. logic supply voltage
	Breakdown voltage	30 V								30 V				
	Output current, Max.	25 mA								25 mA				
	Max. "OFF-side" leakage current	100 μA								100 μA				
	Max. "ON-side" voltage drop	0.4 V								0.4 V				at max. carrying current

### 2. Output module

		OAC 3/15	OAC 4/15-L	OAC 10/32	OAC 10/32-L	OAC 3/15-A	OAC 4/15-AL	OAC 10/32-A	OAC 10/32-AL	ODC 3/15	ODC 4/15-L	ODC 10/32	ODC 10/32-L	ODC 3/15-A	ODC 4/15-AL	ODC 10/32-A	ODC 10/32-AL	Remarks
Logic side	Logic voltage range	3 to 15 V	4 to 15 V	10 to 32 V		3 to 15 V	4 to 15 V	10 to 32 V		3 to 15 V	4 to 15 V	10 to 32 V		3 to 15 V	4 to 15 V	10 to 32 V		
	Input Impedance (Approx.)	1.6 kΩ	1.7 kΩ	6 kΩ	5 kΩ	1.6 kΩ	1.7 kΩ	6 kΩ	5 kΩ	1.6 kΩ	1.7 kΩ	6 kΩ	5 kΩ	1.6 kΩ	1.7 kΩ	6 kΩ	5 kΩ	*1
	Drop-out voltage, Min.	0.8V								0.8V								
Output side	Max. load current	2 A (Ambient temperature: Max. 30°C)*2								2 A (Ambient temperature: Max. 40°C)*2				1 A (Ambient temperature: Max. 40°C)*2				
	Output voltage	75 to 125 V AC				75 to 250 V AC				3 to 60 V DC				10 to 200 V DC				
	Non-repetitive surge current	30 A (in one cycle at 60 Hz)*3								5 A (for 1 s)*3								
	Max. "OFF-state" leakage current	5 mA (100 V)				5 mA (200 V)				1 mA (60 V)				1 mA (200 V)				at 60 Hz
	Max. "ON-state" voltage current	1.6 V								1.6 V				2.3 V				at max. carrying current
	Min. load current	50 mA*4								5 mA*4								

Notes: \*1. Please refer to REFERENCE DATA, "3. Input current vs. input voltage".

\*2. Please refer to REFERENCE DATA, "1. Load current vs. ambient temperature".

\*3. Please refer to REFERENCE DATA, "2. Surge current vs. time".

\*4. When the load current is less than the rated minimum load current, please refer to "Cautions for Use of SSR".

### Characteristics (at 20°C 68°F, Voltage ripple of logic side: less than 1%)

		Input modules				Output modules				
		IAC		IDC		OAC		ODC		
Operate time, max.		20 ms		5 ms		1/2 cycle of voltage sine wave + 1 ms		0.5 ms		
Release time, max.		20 ms		5 ms		1/2 cycle of voltage sine wave + 1 ms		2 ms		
Insulation resistance		10 <sup>9</sup> Ω between input and output (at 500 V DC)								
Breakdown voltage		4,000 V AC between input and output (for 1 min.)								
Vibration resistance	Destructive	10 to 55 Hz at double amplitude of 2 mm (1 hour for X, Y, Z axis)								
	Functional	10 to 55 Hz at double amplitude of 2 mm (10 minutes for X, Y, Z axis)								
Shock resistance	Destructive	Min. 980 m/s <sup>2</sup> {100G} (5 times each for X, Y, Z axis)								
	Functional	Min. 980 m/s <sup>2</sup> {100G} (4 times each for X, Y, Z axis)								
Ambient temperature		-30°C to +80°C -22°F to +176°F				-30°C to +80°C -22°F to +176°F				
Storage temperature		-30°C to +100°C -22°F to +212°F				-30°C to +100°C -22°F to +212°F				
Operational method		-				Zero-cross (Turn-ON and Turn-OFF)				-

## REFERENCE DATA

1-1. Load current vs. ambient temperature (OAC)

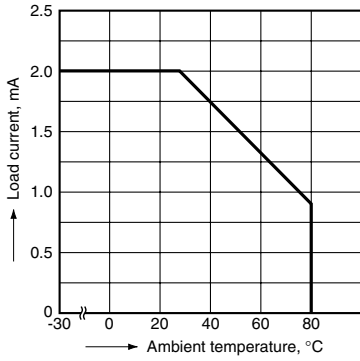

1-2. Load current vs. ambient temperature (ODC)

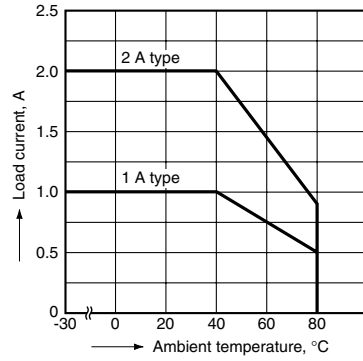

2-1. Surge current vs. time (OAC)

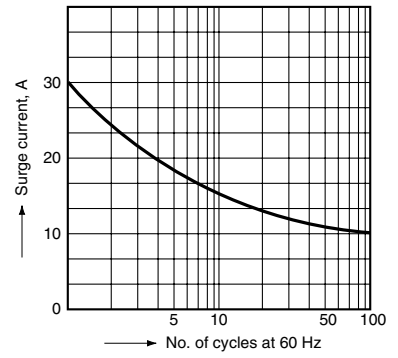

2-2. Surge current vs. time (ODC)

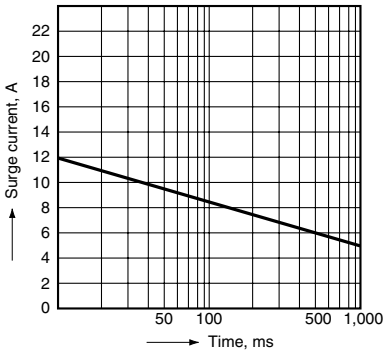

3. Input current vs. input voltage (OAC, ODC)

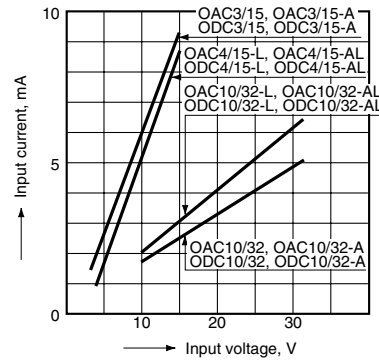

## DIMENSIONS (mm inch)

The CAD data of the products with a **CAD Data** mark can be downloaded from: <http://panasonic-electric-works.net/ac>

### Input module (IAC, IDC)

**CAD Data**

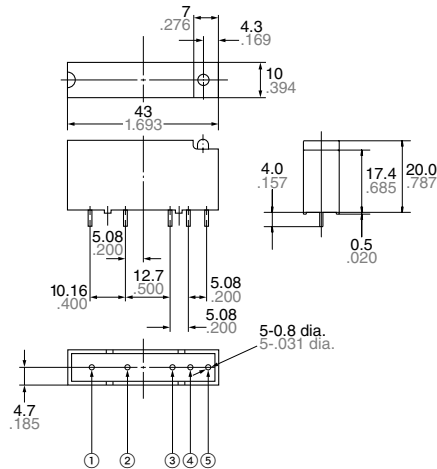

### PC board pattern (Bottom view)

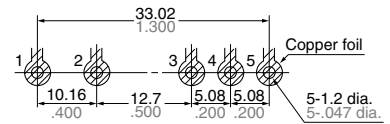

	IAC	IDC
1	Input: AC	Input: DC +
2	Input: AC	Input: DC -
3	Vcc	Vcc
4	Logic output	Logic output
5	Grounding	Grounding
Body color	Yellow	White

### Output modules (OAC, ODC)

**CAD Data**

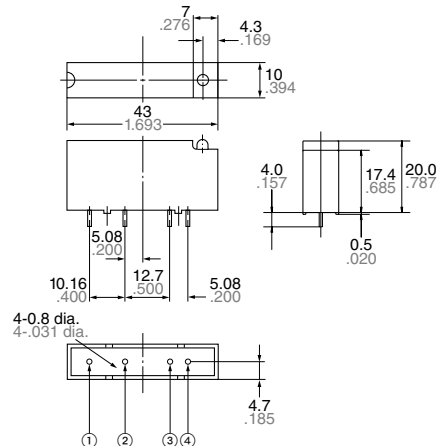

### PC board pattern (Bottom view)

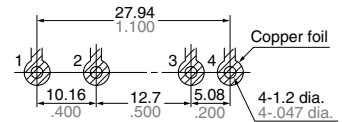

	OAC	ODC
1	Output: AC	Output: DC +
2	Output: AC	Output: DC -
3	Input: DC+	Input: DC+
4	Input: DC-	Input: DC-
Body color	Black	Red

# BLOCK DIAGRAM

## 1) AC input module

Without LED

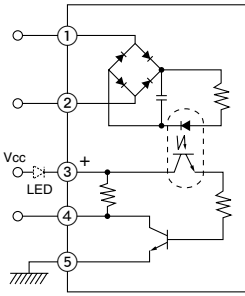

With LED

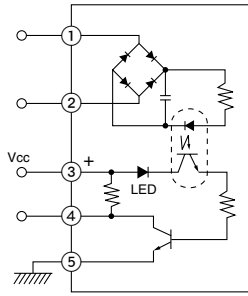

## 2) DC input module

Without LED

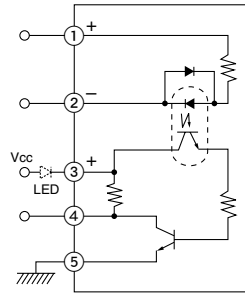

With LED

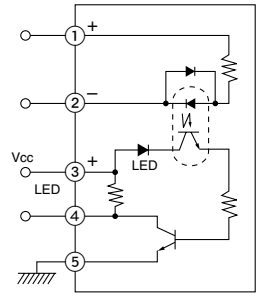

## 3) AC output module

Without LED

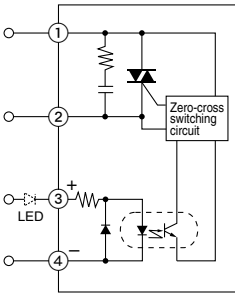

With LED

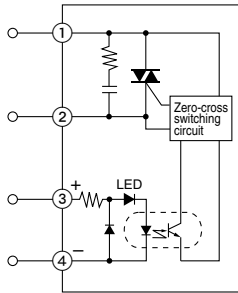

## 4) DC output module

Without LED

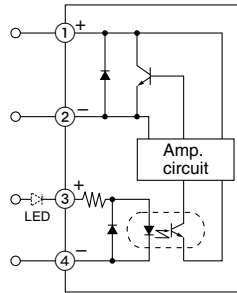

With LED

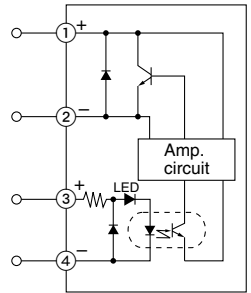

# ACCESSORIES

## I/O Socket

**CAD Data**



I/O-PS

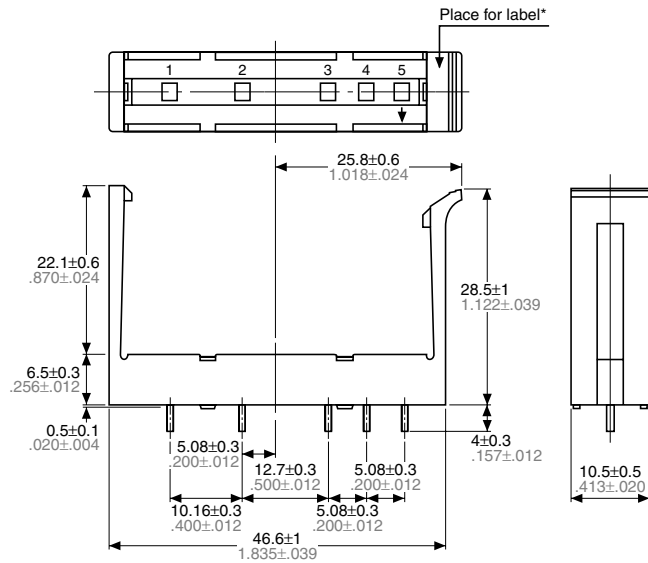

## PC board pattern (Bottom view)

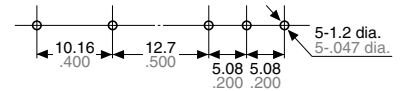

\* Use the included label. Affixing it here on the socket will facilitate viewing of the circuit and other tasks.

## For Cautions for Use.